



CURTIS



# On-Road AC Motor Controller

## Model 1239E

### e series



CE



# Model 1239E



## On-Road AC Motor Controller

**The 'E' difference** A significant enhancement to the Curtis AC family, The 'E' models utilize a powerful dual-microprocessor logic architecture to provide improved performance and surpass the requirements of the latest international functional safety standards.

The Curtis Model 1239E provides energy efficient control of asynchronous AC induction motors performing on-vehicle traction drive duties. It offers vehicle developers a highly cost-effective combination of power, performance and functionality.

Intended for electric and hybrid vehicles using 60–144V nominal system voltage for high power circuits, and a 12V chassis-grounded system for low-power control circuits. Software upgrade allows use with surface permanent magnet synchronous motors. Please contact Curtis technical support for more information.

### ONLY CURTIS AC CAN OFFER:

- ▶ **Curtis VCL™—Vehicle Control Language** is an easy to use programming language that allows vehicle developers to write powerful logic functions and create a 'virtual system controller'. Curtis offers customers VCL development tools and training. Curtis also provides a VCL service where Curtis engineers will work with the OEM to create any custom VCL code required.
- ▶ **Indirect Field Orientation (IFO) vector control** algorithm generates the maximum possible torque and efficiency across the entire speed range. Advanced Curtis IFO vector control provides superb drive 'feel', improved speed regulation and increased gradeability.
- ▶ **Curtis Auto-Tune** function enables quick and easy characterization of the AC motor without having to remove it from the vehicle. Curtis AC controllers are fully compatible with any brand of AC motor.
- ▶ **Dual-Drive functionality** is standard, allowing correct control of applications featuring twin traction motors. This function ensures smooth and safe operation, minimal tire wear and correct load sharing between the traction motors at all times.
- ▶ **Configurable CANbus** connection allows high-speed communication with other CANbus enabled devices. Model 1239 is CANopen compatible and can be further customized and configured using VCL for use with any 11-bit or 29-bit Bosch CAN Part 2A/B protocol.
- ▶ **Integrated System Controller**—More than just a motor controller, it is also powerful system controller. It features a comprehensive allocation of multi-function I/O pins for use as analog inputs, digital inputs, contactor coil drivers and proportional valve drivers. In addition to this local I/O, this controller can use VCL to map and configure the remote I/O available on other CANbus devices, send messages to CAN displays and thus control and monitor the entire system.



# Model 1239E

## On-Road AC Motor Controller



### FEATURES

#### Increased Performance, Improved Functionality

- ▶ Isolated logic section allows all control I/O to run off the vehicle's auxiliary 12V supply.
- ▶ Programmable isolation monitoring and fault detection.
- ▶ CE marked as a programmable safety device under EN ISO 13849-1.
- ▶ Models available delivering 500–650Arms output for 60–144V nominal voltage systems.
- ▶ Powerful CAN master capabilities.

#### Advanced Functionality, Compact Power

- ▶ High frequency, silent operation across the 0–400Hz stator frequency range.
- ▶ 1500Vac electrical isolation to heatsink/chassis meets IS06469-3 requirements.
- ▶ Automatic capacitor discharge on key-off.
- ▶ Powerful operating system allows parallel processing of vehicle control tasks, motor control tasks and user configurable programmable logic.
- ▶ Advanced Pulse Width Modulation techniques produce low motor harmonics, low torque ripple and minimized heating losses, resulting in high efficiency.

#### Unmatched Flexibility

- ▶ Field upgradeable software.
- ▶ Integrated Battery state-of-charge algorithm and hour meter.
- ▶ Programmable user-selectable vehicle operating profiles.
- ▶ Comprehensive programming options and VCL allow easy modification of functionality to suit each application.
- ▶ Curtis hand-held or PC Windows programming tools provide easy programming and powerful system diagnostic tools such as data logging, monitor and graph functions.
- ▶ Integrated status LED provides instant diagnostic indication.

#### Robust Safety and Reliability

- ▶ Insulated Metal Substrate power base provides superior heat transfer for increased reliability.
- ▶ Fail-Safe power component design.
- ▶ Powerful supervisor microprocessor continuously tests all safety related parts of the control system.
- ▶ Reverse polarity protection on battery connections.
- ▶ Short circuit protection on all output drivers.
- ▶ Thermal cutback, warning, and automatic shutdown provide protection to motor and controller.
- ▶ Rugged sealed housing and connectors meet IP65 environmental sealing standards for use in harsh environments.

#### Meets or complies with relevant US and International Regulations

- ▶ EMC: designed to the requirements of EN12895 with regard to radiated emissions and immunity.
- ▶ Safety: Designed to the requirements of EN1175-1:1998+A1:2010 EN (ISO) 13849-1
- ▶ IP65 rated per IEC 60529.
- ▶ Regulatory compliance of the complete vehicle system with the controller installed is the responsibility of the vehicle OEM.
- ▶ Complies with UL840 creepage & clearance requirements.



# Model 1239E

## On-Road AC Motor Controller



### FUNCTIONAL SAFETY DATA

Safety Function	PL	Designated Architecture	MTTFd	DC
Uncommanded Powered Movement	d	Category 2	≥36 yrs	≥90%
Motor Braking Torque	c	Category 2	≥12yrs	≥90%

### MODEL CHART

Model	Nominal Voltage (V)		Max Voltage (V)		Min Voltage (V)		Peak Current (Arms)	S2-60 min Current (Arms)
	Power	Logic	Power	Logic	Power	Logic		
1239E-65xx	60-84	12	105	20	33.6	8.4	550 (2min)	155
1239E-76xx	72-108	12	120	20	50.4	8.4	650 (2 min)	200
1239E-85xx	72-144	12	170	20	50.4	8.4	500 (1 min)	135

### SYSTEM ACCESSORIES



The Curtis enGage® VII is a full color, customizable, microprocessor based CANbus Instrument that can be programmed to monitor, display and control numerous vehicle functions in a single integrated package.



The Curtis Acuity Battery Monitoring System is a device that mounts directly to the vehicle battery. It measures, records and transmits battery performance data over the vehicle's CAN network throughout the battery's life.



The Curtis Model 1313 Handheld Programmer is ideal for setting parameters and performing diagnostic functions.

Contact Curtis to obtain the VCL Vehicle Control Language compiler and development tools.

# Model 1239E

## On-Road AC Motor Controller



### CONNECTOR WIRING

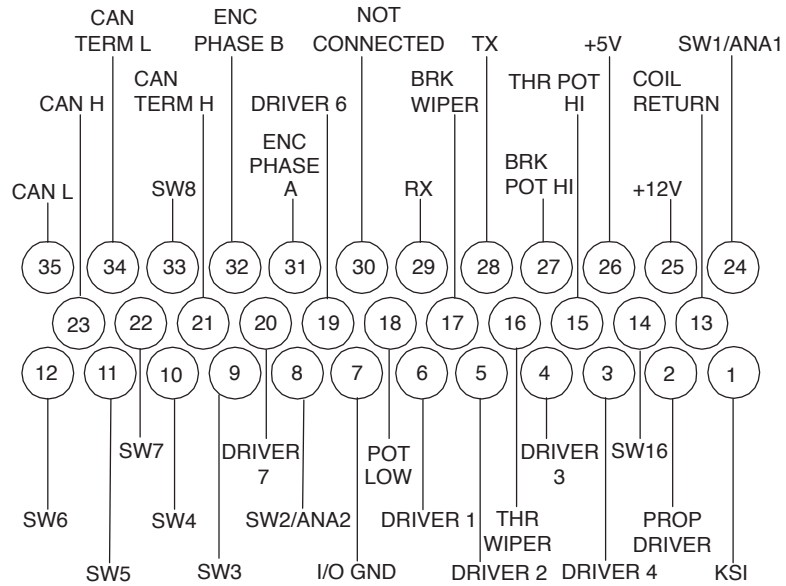

### DIMENSIONS mm

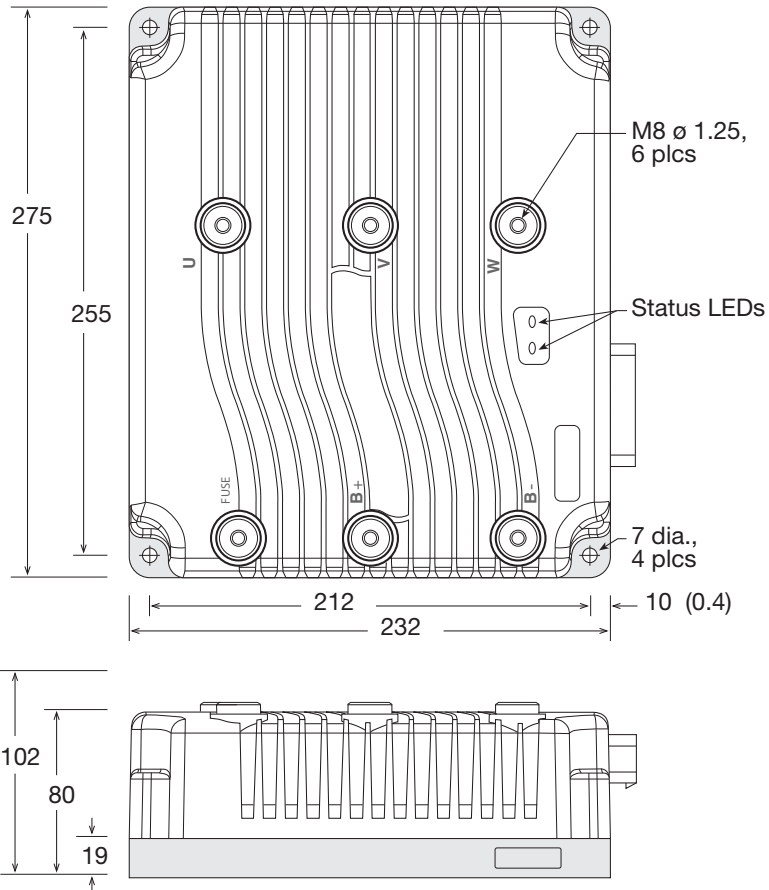

# Model 1239E

## On-Road AC Motor Controller



### TYPICAL WIRING

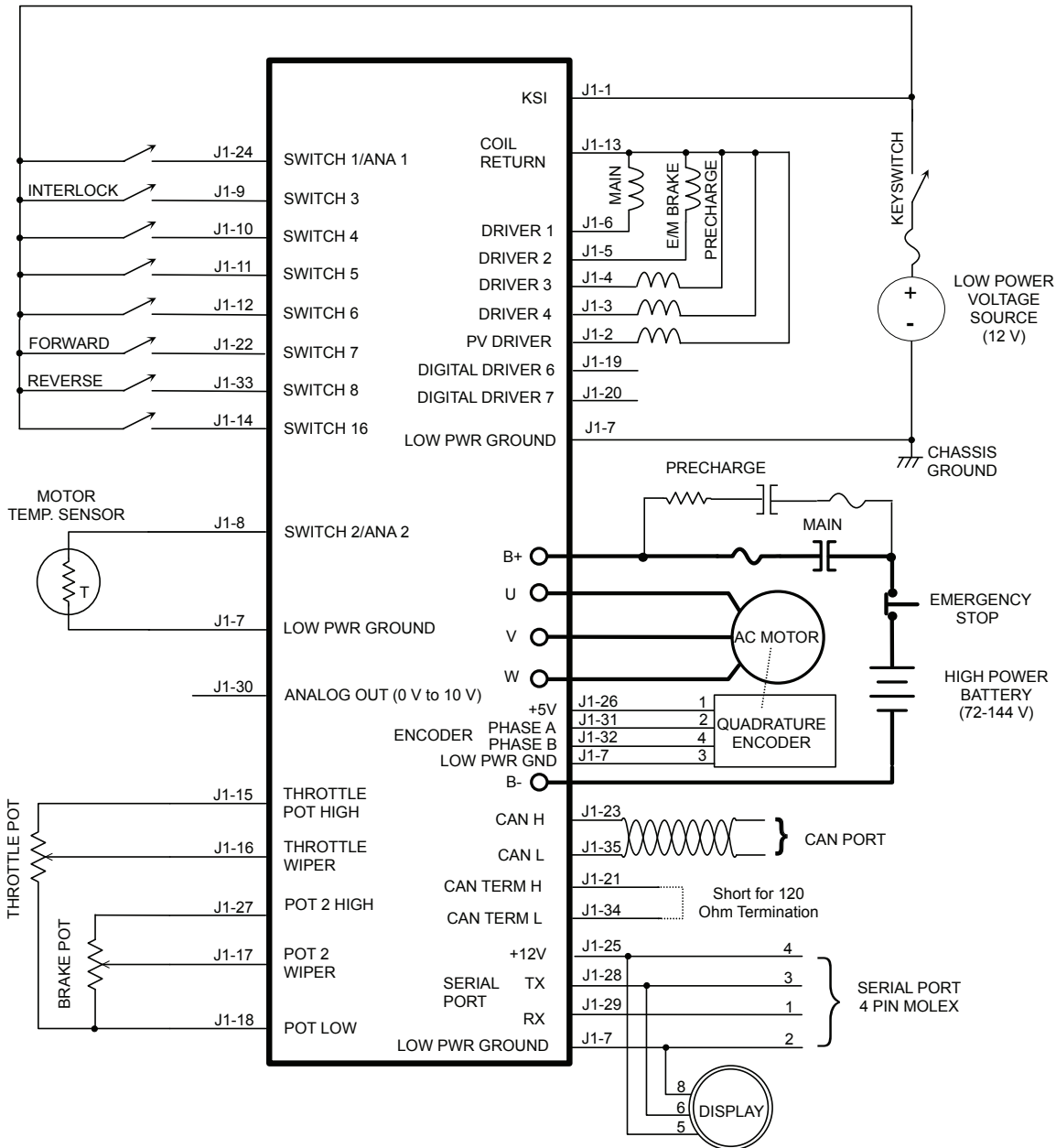

**WARRANTY** Two year limited warranty from time of delivery.

The Curtis Difference  
**You feel it when you drive it**



is a trademark of Curtis Instruments, Inc.

Specifications subject to change without notice

©2016 Curtis Instruments, Inc.

50208 REV C 9/16